

Operations Manual

DPR3000 - Dual Pass Dough Sheeter

Model #: DPR3000



PROLUXE
WWW.PROLUXE.COM

Version: 072125

Congratulations on your selection of the Dual Pass Dough Sheeter is a leading manufacturer of food preparation and cooking equipment designed for the most demanding commercial kitchens. Proluxe equipment is a result of the highest quality engineering and time-tested design.

This manual includes installation, operation, and maintenance procedures for your new dough sheeter. Please read this manual carefully and keep it with your machine and is the key to proper operation and lasting service.

Electrical:
208V/50-60Hz/2800W/13.5 Amps
1 phase

Also available; specify when ordering:

- Voltage: 208
- Amps: 13.5/14.2
- Watts: 2800

Includes: 72" cord and 6-30P NEMA approved plug.

Shipping Weight:
88lbs. (39kg)

INTERNATIONAL SYMBOLS

Symboles internationaux



Power Off
éteindre



Power On
allumer



Hot Surface
surface chaude



Risk of Electrical Shock
Risque de choc électrique



Protective Earth Terminal
Borne de terre de protection



Caution - Warning
chaud - avertissement

SAFETY SUMMARY



Warning

To reduce the risk of electrical shock, do not remove or open cover. No user-serviceable parts inside. Refer servicing to qualified personnel.

Avertissement

Pour réduire le risque de choc électrique, ne pas retirer ou couvercle ouvert Aucune pièce réparable par l'utilisateur, reportez-vous à du personnel qualifié.



Warning

In case of power cord damage, do not attempt to repair or replace the power cord. Please contact the manufacturer or the local distributor.

Avertissement

Pour une protection continue contre l'incendie et de choc électrique, remplacer avec le même type et calibre du fusible. Mis fusible supplémentaire nominale max 3A, 120 Vac.



Warning

For continued protection against fire and electric shock, replace with the same type and rating fuse. Listed Supplemental Fuse rated max 3A, 120Vac.

Avertissement

Pour une protection continue contre l'incendie et de choc électrique, remplacer avec le même type et calibre du fusible. Mis fusible supplémentaire nominale max 3A, 120 Vac.



Caution Hot

Avoid touching hot surfaces while operating the machine.

Attention à chaud

Évitez de toucher les surfaces chaudes lorsque vous utilisez la machine.



Caution

When servicing or cleaning the machine, make sure that the power cord is removed from the wall socket.

During normal operation, the base of the machine must be installed or placed above the wall socket.

Avertissement

Lors de l'entretien ou du nettoyage de la machine, assurez-vous que le cordon d'alimentation est débranché de la prise murale.

GETTING STARTED

Please read carefully before attempting to use this appliance. DO NOT touch hot surfaces.

1. Carefully unpack and clean platen with mild soap and wipe clean with water.
2. Place in location where it will be used allowing for clearances per the dimensions.
3. Plug into proper 208V wall outlet. If other appliances are connected to the same circuit make sure the total load does not exceed maximum ampacity of the circuit.

HOW TO OPERATE

Guidelines for operating your new dough roller safely:

1. Once the doughballs have been preportioned & floured, place a small amount of flour in the hopper and on the receiving table. Next, place the dough ball in the hopper.
2. Pass 1. The dough ball will be partially flattened and semi-oblong, rolling out on the floured receiving table.
3. Pass 2 Is just like the first pass, but this time, turn the dough 90 degrees left or right, inserting it into the bottom rollers.
4. After the dough ball is rolled out, place hands or receiving tray beneath

the bottom chute. Lightly stretch dough to the desired size after placing it directly onto a pan, screen, or peel.

HOW TO CLEAN

Proluxe machines are relatively maintenance free. For a long lifespan, please follow the following care procedures.

1. Unplug the unit before cleaning.



2. Loosen the screws to open the safety shield.



3. Detach springs at each end.



4. Remove all scrapers.



5. Clean rollers, scrapers, tray, and machine housing with mild soap and wipe clean with a damp cloth.



6. Re-attach the scrapers and springs.



7. Tighten the screws on the safety shield.

Service Problems

Contact our factory at (800) 624-6717 (U.S. only) or an approved service agency. When contacting the factory for information, parts, or service instructions, please provide the serial number of the machine.

This number can be found on the serial plate located on the rear of the machine.

PROLUXE

DPR3000

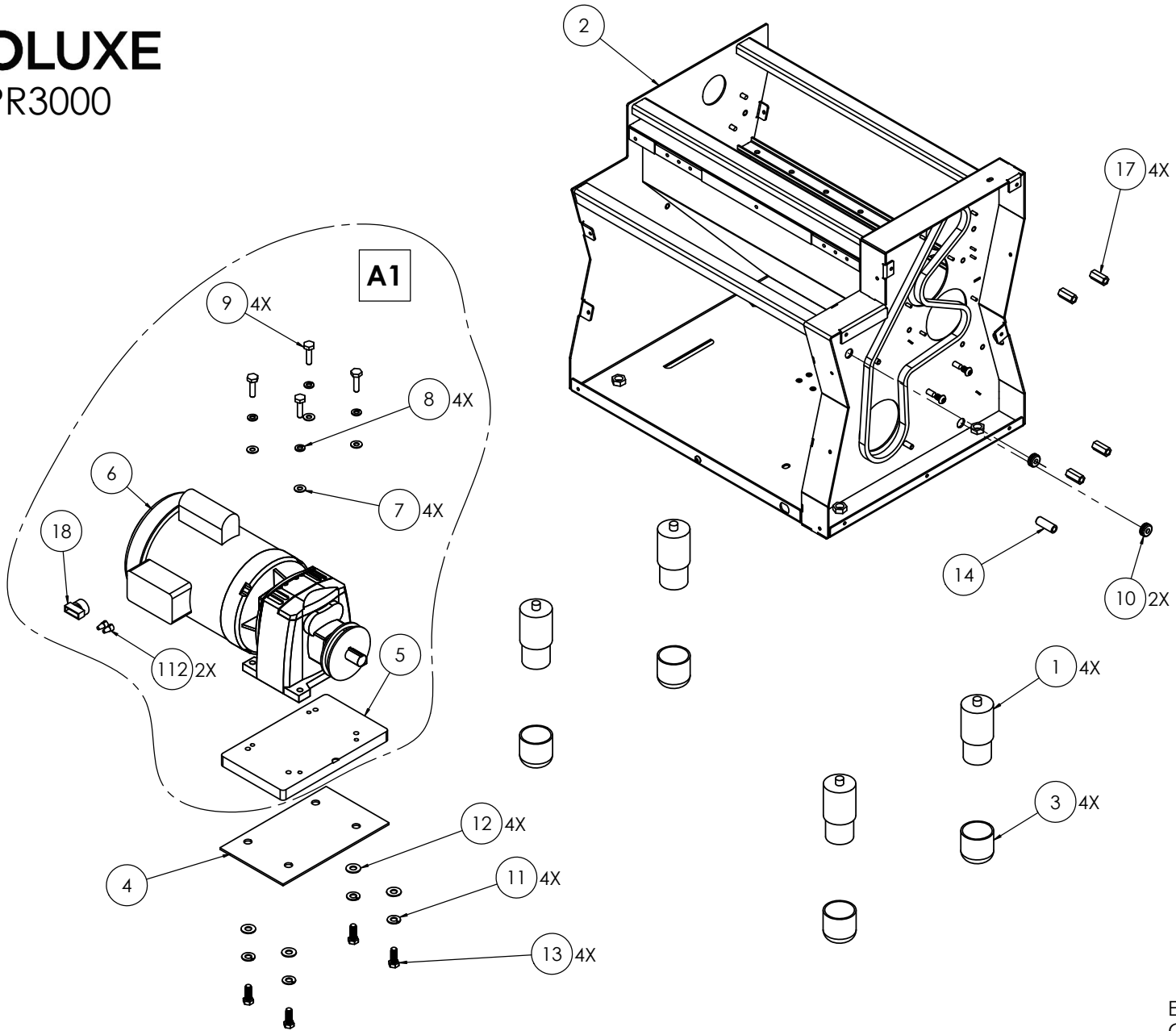

PROLUXE

DPR3000

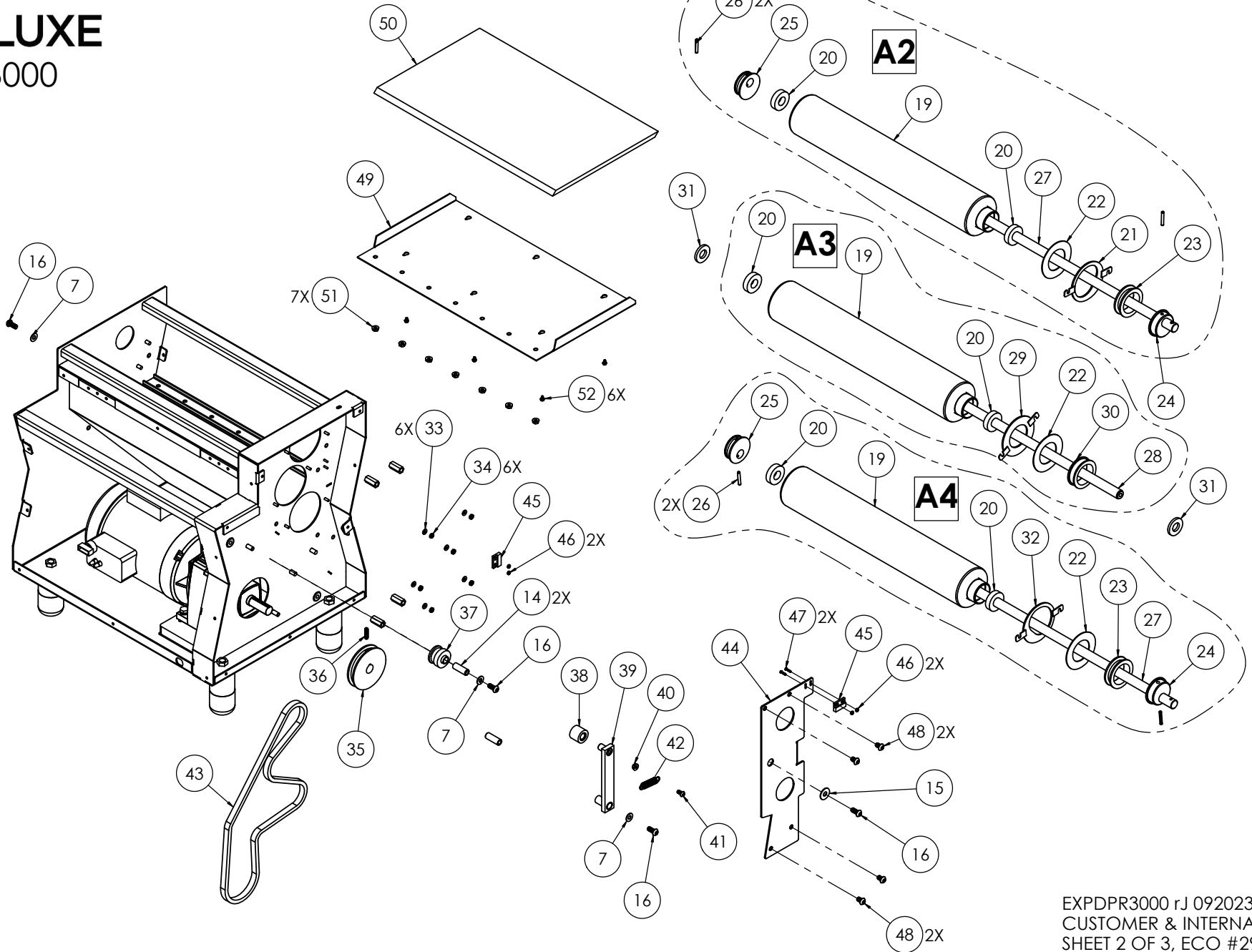

PROLUXE

DPR3000

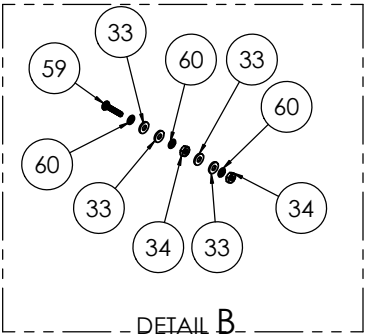
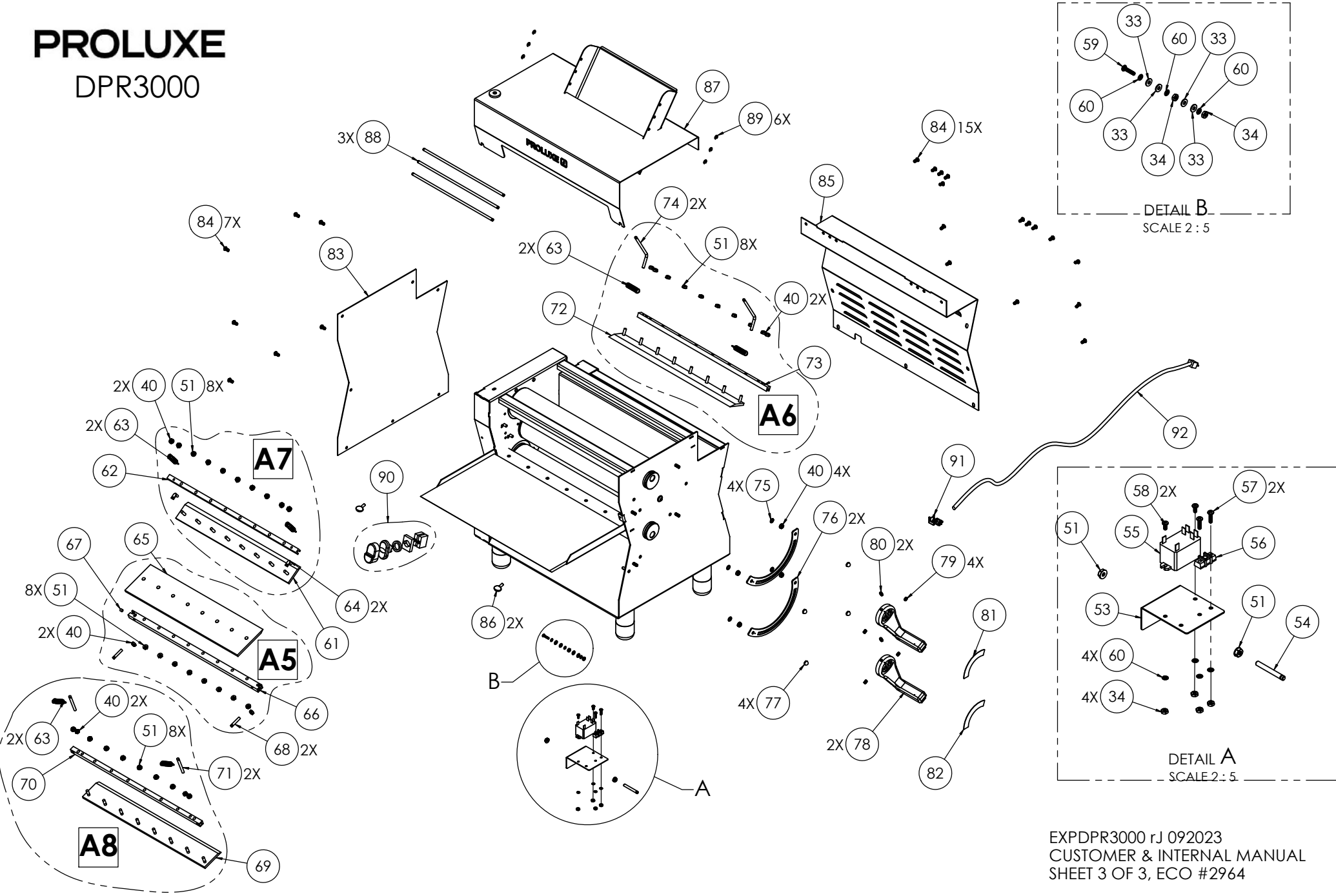

DETAIL B
SCALE 2 : 5

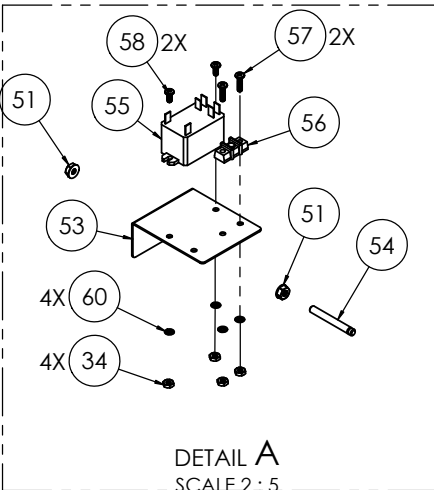

DETAIL A
SCALE 2 : 5

PARTS LIST FOR DPR3000

ITEM NO.	DESCRIPTION	DPR3000A 120V	DPR3000MEA 120V	DPR3000B 240V	DPR3000CEC 220V	QTY.
1	ADJUSTABLE LEG	1101097091	1101097091ME	1101097091	1101097091	4
2	DOUGH ROLLER WELDING ASSEMBLY	11017457610	11017457610	11017457610	11017457610	1
3	RUBBER FOOT	1101097096	1101097096	1101097096	1101097096	4
4	PAD, VIBRATION DAMPENING	1101745768001	1101745768001	1101745768001	1101745768001	1
5	MOTOR BASE	110623006	110623006	110623006	110623006	1
6	Gearmotor 1/3 HP 1 PHASE 3/4" SHAFT	1101097134	1101097134	1101097134	1101097136	1
7	WASHER, SAE 5/16	WSAE516	WSAE516	WSAE516	WSAE516	7
8	WASHER, LOCK 5/16	WL516	WL516	WL516	WL516	4
9	HEX BOLT 5/16-18 X 1 1/4 STAINLESS STEEL	BH51618114S	BH51618114S	BH51618114S	BH51618114S	4
10	GROMMET	110969116	110969116	110969116	110969116	2
11	WASHER, LOCK 3/8	WL38	WL38	WL38	WL38	4
12	WASHER, SAE 3/8	WSAE38	WSAE38	WSAE38	WSAE38	4
13	HEX BOLT 3/8-16 X 1 STAINLESS STEEL	BH38161S	BH38161S	BH38161S	BH38161S	4
14	THREADED SPACER	1101097074	1101097074	1101097074	1101097074	2
15	WASHER, CUT 5/16	WC516	WC516	WC516	WC516	1
16	SCREW, BUTTON HEAD 5/16-18 X 3/4	SB5161834	SB5161834	SB5161834	SB5161834	4
17	HEX COUPLING 5/16-18 X 1-1/8	1101097094	1101097094	1101097094	1101097094	4
18	CONNECTOR, 1/2" MALE X 3/8" CLAMP	100455167	100455167	100455167	100455167	1
19	TOP ROLLER SUB ASSEMBLY	1101097021	1101097021	1101097021	1101097021	3
20	DOUBLE SEALED BEARING	1101097026	1101097026	1101097026	1101097026	6
21	TOP ROLLER BRACKET	1101097023	1101097023	1101097023	1101097023	1
22	PLASTIC GUARD	1101097103	1101097103	1101097103	1101097103	3
23	PULLEY, ROLLER UPPER AND LOWER	1101097139	1101097139	1101097139	1101097139	2
24	LEFT SIDE CAM	1101097030	1101097030	1101097030	1101097030	2
25	RIGHT SIDE CAM	1101097029	1101097029	1101097029	1101097029	2
26	PIN, ROLL 3/16 X 1-1/4	PR316114	PR316114	PR316114	PR316114	4
27	UPPER & LOWER ROLLER SHAFT	1101097027	1101097027	1101097027	1101097027	2
28	MIDDLE ROLLER SHAFT	1101097033	1101097033	1101097033	1101097033	1
29	MIDDLE ROLLER BRACKET ASSEMBLY	1101097034	1101097034	1101097034	1101097034	1
30	PULLEY, MIDDLE ROLLER	1101097140	1101097140	1101097140	1101097140	1
31	MIDDLE ROLLER SPACER	1101097105	1101097105	1101097105	1101097105	2
32	BOTTOM ROLLER BRACKET	1101097036	1101097036	1101097036	1101097036	1
33	WASHER, SAE #8	WSAE8	WSAE8	WSAE8	WSAE8	10
34	NUT, HEX 8-32	NH832	NH832	NH832	NH832	12
35	PULLEY, MOTOR	1101097138	1101097138	1101097138	1101097138	1
36	SCREW, SET 1/4-20 X 1.0	SST14201	SST14201	SST14201	SST14201	1
37	PULLEY, IDLER ASEMBLY	1101097124	1101097124	1101097124	1101097124	1
38	PULLEY, IDLER TENSIONER ASSEMBLY	1101097123	1101097123	1101097123	1101097123	1
39	TENSIONER BAR ASSEMBLY	1101097009	1101097009	1101097009	1101097009	1
40	NUT, HEX 1/4-20	NH1420	NH1420	NH1420	NH1420	13
41	SCREW, BUTTON HEAD 1/4-20 X 1/2	SB142012	SB142012	SB142012	SB142012	1
42	SPRING, EXTENSION 1/2" O.D. X 3.0" LONG X 1/16" THICK	SE123116	SE123116	SE123116	SE123116	1

PARTS LIST FOR DPR3000

ITEM NO.	DESCRIPTION	DPR3000A 120V	DPR3000MEA 120V	DPR3000B 240V	DPR3000CEC 220V	QTY.
43	BELT, V-TYPE 1/2" WIDE X 5/16" THICK X 47" LONG	BV1251647	BV1251647	BV1251647	BV1251647	1
44	BELT GUARD	11017457604	11017457604	11017457604	11017457604	1
45	PROXIMITY SWITCH SENSOR	1101097082	1101097082	1101097082	1101097082	2
46	NUT, HEX 4-40	NH440	NH440	NH440	NH440	4
47	SCREW, ROUND HEAD 4-40 X 1/2"	SR44012	SR44012	SR44012	SR44012	2
48	SCREW, BUTTON HEAD 5/16-18 X 1/2	SB5161812	SB5161812	SB5161812	SB5161812	4
49	IN-TAKE TRAY SHELF SUB ASSEMBLY	1101097037	1101097037	1101097037	1101097037	1
50	INTAKE TRAY	1101097040	1101097040	1101097040	1101097040	1
51	NUT, SERRATED FLANGED HEX, 1/4-20	NHSF1420	NHSF1420	NHSF1420	NHSF1420	41
52	SCREW, SHEET METAL #8 X 5/16, HEX WASHER HD SLOTTED	SMS8516	SMS8516	SMS8516	SMS8516	6
53	RELAY BRACKET	1101097080	1101097080	1101097080	1101097080	1
54	PIN, TENSION SPRING	1101097079	1101097079	1101097079	1101097079	1
55	RELAY, TERMS 30A 250V	1101097081	1101097081	1101097081230	1101097081230	1
56	TERMINAL, BLOCK #1 SINGLE	6991	6991	6991	6991	1
57	SCREW, PAN HEAD PHILLIPS 8-32 X 5/8	SP83258	SP83258	SP83258	SP83258	2
58	SCREW, PAN HEAD PHILLIPS 8-32 X 3/8	SP83238	SP83238	SP83238	SP83238	2
59	SCREW, PAN HEAD PHILLIPS 8-32 X 3/4 STAINLESS STEEL	SP83234S	SP83234S	SP83234S	SP83234S	1
60	WASHER, INTERNAL LOCK #8	WLIT8	WLIT8	WLIT8	WLIT8	7
61	TOP FRONT SCRAPER #2 SUB ASSEMBLY	1101097056	1101097056	1101097056	1101097056	1
62	TOP FRONT SCRAPER #2 BAR	1101097057	1101097057	1101097057	1101097057	1
63	EXTENSION SPRING SCRAPER	1101097052	1101097052	1101097052	1101097052	6
64	ANGULAR WELD STUD MACHINED	1101097101	1101097101	1101097101	1101097101	2
65	MIDDLE FRONT SCRAPER #3 SUB ASSEMBLY	1101097062	1101097062	1101097062	1101097062	1
66	MIDDLE FRONT SCRAPER #3 BAR	1101097063	1101097063	1101097063	1101097063	1
67	MAGNET DISC 1/4" DIA	110601065	110601065	110601065	110601065	1
68	MIDDLE FRONT SCRAPER #3 SPRING PIN	1101097064	1101097064	1101097064	1101097064	2
69	BOTTOM FRONT SCRAPER #4 SUB ASSEMBLY	1101097069	1101097069	1101097069	1101097069	1
70	BOTTOM FRONT SCRAPER #4 BAR	1101097070	1101097070	1101097070	1101097070	1
71	SPRING PIN FOR #4 SCRAPER	1101097071	1101097071	1101097071	1101097071	2
72	BACK SCRAPER #1 SUB ASSEMBLY	1101097049	1101097049	1101097049	1101097049	1
73	BACK SCRAPER #1 BAR	1101097050	1101097050	1101097050	1101097050	1
74	BACK SCRAPER #1 SPRING PIN	1101097051	1101097051	1101097051	1101097051	2
75	WASHER, SAE 1/4	WSAE14	WSAE14	WSAE14	WSAE14	4
76	ADJUSTMENT PLATE	1101097119	1101097119	1101097119	1101097119	2
77	NUT, ACCORN 1/4-20 NICKLE PLATE	NA1420	NA1420	NA1420	NA1420	4
78	HANDLE ADJUSTMENT ASSEMBLY	1101097118	1101097118	1101097118	1101097118	2
79	SCREW, SET 1/4-20 X 3/8	SST142038	SST142038	SST142038	SST142038	4
80	SCREW, SET 1/4-20 X 1/2	SST142012	SST142012	SST142012	SST142012	2
81	TOP ROLLER GAGE DECAL	DP110109720T	DP110109720T	DP110109720T	DP110109720T	1
82	BOTTOM ROLLER GAGE DECAL	DP110109720B	DP110109720B	DP110109720B	DP110109720B	1
83	COVER, LEFT SIDE	11017457602	11017457602	11017457602	11017457602	1
84	SCREW, BUTTON HEAD 1/4-20 X 1/2 STAINLESS STEEL	SB142012S	SB142012S	SB142012S	SB142012S	22

PARTS LIST FOR DPR3000

ITEM NO.	DESCRIPTION	DPR3000A 120V	DPR3000MEA 120V	DPR3000B 240V	DPR3000CEC 220V	QTY.
85	BACK COVER	1101097131	1101097131	1101097131	1101097131	1
86	THUMB SCREW WITH SHOULDER	1101097086	1101097086	1101097086	1101097086	2
87	SAFETY COVER ASSEMBLY	11017457603	11017457603	11017457603	11017457603	1
88	SAFETY BAR	1101097044	1101097044	1101097044	1101097044	3
89	E-CLIP 1/4"	1101097045	1101097045	1101097045	1101097045	6
90	START-STOP COMBINATION BUTTON, W/EXTENDED STOP	1101097083	1101097083	1101097083	1101097083	1
91	STRAIN RELIEF	MPSS168	MPSS168	MPSS168	MPSS168	1
92	POWER CORD	110969174	110969174	110969175	MPPW202	1
95	DECAL DISCONNECT POWER, SUPPLY	DP1101097098	DP1101097098	DP1101097098	DP1101097098	1
111	MANUAL DPR3000	M DPR3000	M DPR3000	M DPR3000	M DPR3000	1
112	YELLOW NUT WIRE CONNECTOR	WN2210	WN2210	WN2210	WN2210	2
A1	GEAR MOTOR ASSEMBLY	1101097134K	1101097134K	1101097134K	1101097134K	1
A2	ROLLER, TOP ASSEMBLY	1101097129	1101097143	1101097129	1101097129	1
A3	ROLLER, MIDDLE ASSEMBLY	1101097130	1101097144	1101097130	1101097130	1
A4	ROLLER, BOTTOM ASSEMBLY	1101097128	1101097142	1101097128	1101097128	1
A5	MIDDLE FRONT SCRAPER, #3 ASSEMBLY	1101097059	1101097059	1101097059	1101097059	1
A6	BACK SCRAPER, #1 ASSEMBLY	1101097046	1101097046	1101097046	1101097046	1
A7	TOP FRONT SCRAPER, #2 ASSEMBLY	1101097053	1101097053	1101097053	1101097053	1
A8	BOTTOM FRONT SCRAPER, #4 ASSEMBLY	1101097066	1101097066	1101097066	1101097066	1

PROLUXE

DPR2000/DPR3000

ELECTRICAL RATING

115 VOLTS
8.8 AMPS

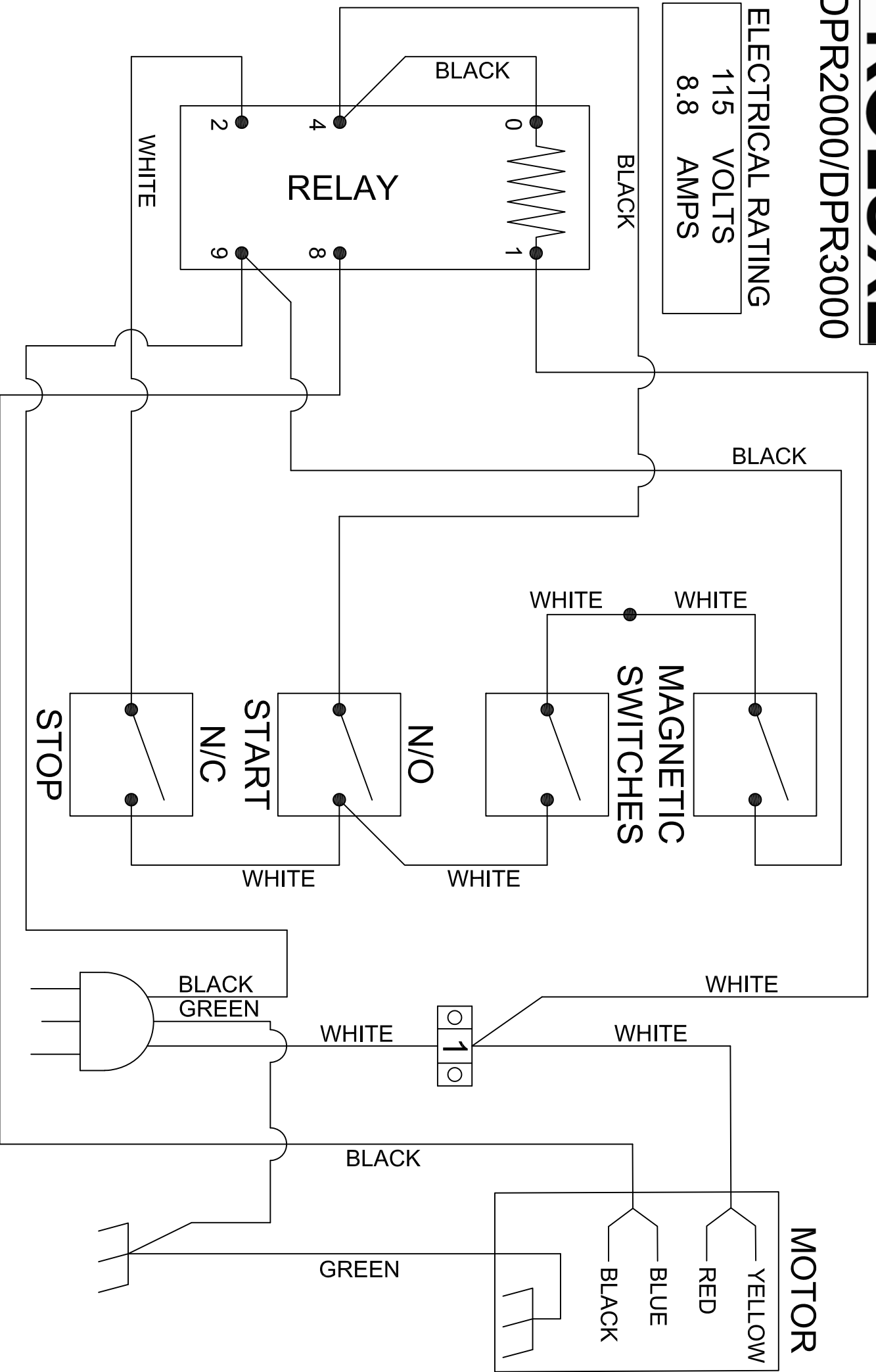

Warranty & Return Policy

Proluxe warrants all products manufactured by it against defects in workmanship or materials from the date of purchase for a period of 1 year on parts and labor. This warranty applies to only equipment purchased and used in the United States.

Warranty period shall begin when equipment ships. Warranty travel will only be covered for 60 miles.

ALL WARRANTY SERVICE CALLS MUST BE APPROVED BY PROLUXE. IF THIS PROCEDURE IS NOT FOLLOWED, WARRANTY SERVICE WILL NOT BE COVERED. WARRANTY SERVICE WILL BE PAID ON STRAIGHT TIME, OVERTIME WILL NOT BE COVERED.

Service Calls

Contact our factory to obtain warranty service. Proluxe must issue a return authorization number, and call tag, or find the name and location of a Factory Authorized Service Center nearest you. When calling for service, please furnish the model number, serial number, and a description of the problem.

EXCLUSIONS

The warranties provided by Proluxe DO NOT apply to the following:

- Damage due to misuse, abuse, alteration, or accident.
- Improper or unauthorized repairs.
- Submerged in water.

- Damaged in shipment.
- Equipment exported to foreign countries.

Special Order Equipment and Accessories

Cannot be canceled and are not returnable unless defective within the terms of this warranty.

In no event shall Proluxe be liable for consequential damages arising out of the failure of any of its products if operated improperly or caused by normal wear or damaged by operator abuse.

Limited Lifetime Warranty on Heating Elements

If replacement is needed, Proluxe will send the new part at no charge but labor will not be covered unless the unit is still under the 1 year manufacturer warranty.

RETURNED MERCHANDISE POLICY

Should it become necessary to return any of the company's products, the following instructions must be adhered to: First, contact our customer service department for approval and a return authorization number. Please have the serial number of your item available at that time. All merchandise must be shipped freight prepaid by customer or service agency. Subject to the inspection of the product by the company, a restocking charge of 20% of the Net purchased price paid to Proluxe will be assessed.

Merchandise may not be returned for credit without prior written approval of Proluxe.

Collect shipments will not be accepted. No returns after 60 days of original shipment date on machines. Purchased parts may not be returned after 30 days. If upon inspection by Proluxe or its authorized agent it is determined the equipment has not been used in an appropriate manner, has been modified, or has not been properly maintained, or has been subject to misuse, misapplication, neglect, abuse, accident, unauthorized modification, damage during transit, delivery, fire, flood, act or war, riot or act of God, then this warranty shall be deemed null and void.

TERMS & CONDITIONS

1. Price List prices are suggested retail prices and are shown in U.S. Dollars.

2. Terms of Payment: 1% 10 days, NET 30 days.

3. New Accounts: Satisfactory credit information must be provided before open account status can be extended.

Unless agreed otherwise, all shipments will be made C.O.D., Cash in advance.

4. Pricing: Prices, specifications, model numbers, capacities and accessories are subject to change without notice.

5. Freight/Routing: Method of shipment will be determined by Proluxe unless otherwise advised by purchaser.

6. Damaged Claims: All merchandise shipped at purchaser's risk. Inspection must be made by purchaser at time goods are received. If goods are damaged, the PURCHASER shall request that the agent of the transportation company make a written notation on the proper shipping documents immediately and then file a claim for damages.

Note: Goods damaged in shipping are non-returnable.

7. Returns: Machines may not be returned after 60 days. Purchased parts may not be returned after 30 days. A restocking fee of 20% will be assessed on non-warranty returns.

8. Taxes: Prices indicated herein DO NOT include State, Federal, Local or foreign taxes or duties, nor do they include fees, permits, insurance or other levies, all of which are the responsibility of the purchaser.

9. All orders are subject to acceptance by Proluxe.

10. Possession of this price list shall not be considered an offer to sell